

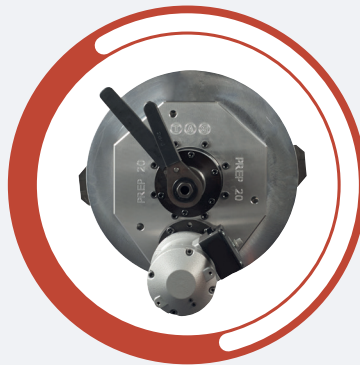

PIPE EQUIPMENT SPECIALISTS LTD

PREP 20 PIPE BEVELLING 4" to 20"

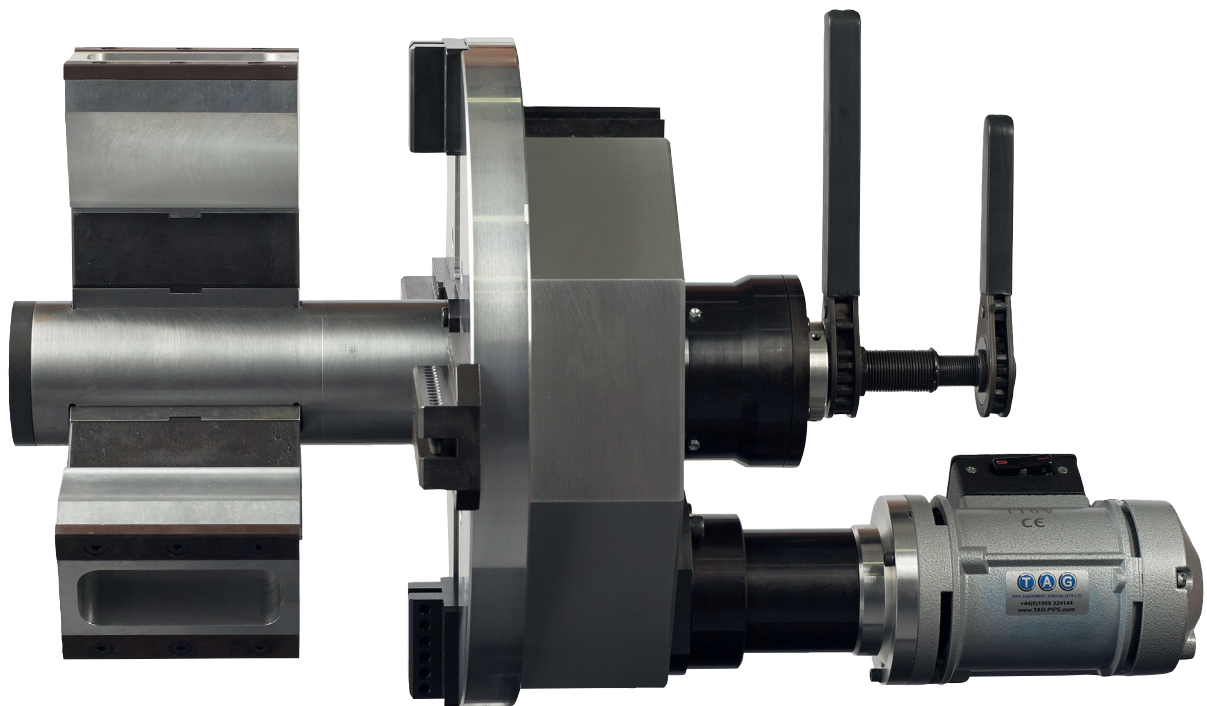

www.TAG-PIPE.COM

Copyright © 2017 TAG PIPE EQUIPMENT SPECIALISTS LTD. All rights reserved.

Tel: +44 (0)1869 324 144
E-mail: sales@tag-pipe.com

RANGE: 100 to 500mm i/d

- **Functions:** External Beveling
Internal Beveling
Facing
Counter-boring
Weld Removal
J-Prepping
Compound Bevels
- **Materials:** Any kind of Steel
and Exotic Alloy
- **Power:** Pneumatic (option of
Electric 110v or 220v)

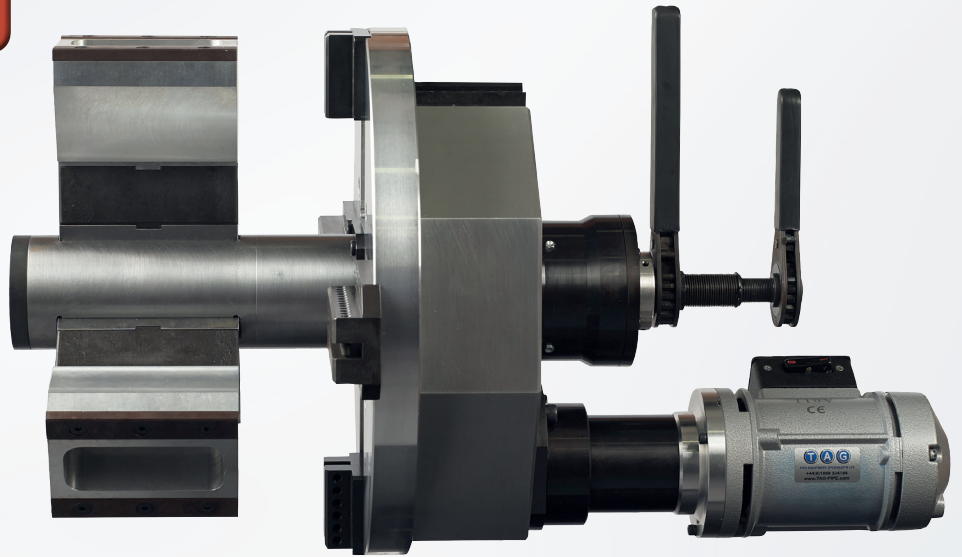

FEATURES & ADVANTAGES

The PREP 20 is the second in TAG's new range of a heavy duty mid-large diameter beveling machines.

Offering ratchet i/d jaw locking, as well as Ratchet bevel feed control for effortless heavy wall preps. Offered with a 3.5 HP Pneumatic boasting 7500Nm Torque or 3200 watt electric motor any bevel geometry can be performed within the impressive 4 - 20" range.

J-preps, counter boring, and facing can all be performed, simultaneously, using the correct tooling fitted in (up to) 4 heavy duty hardened multi-position tool holders. Due to its light weight, yet unrivalled power, the PREP 20 is ideal for on-site, off shore, nuclear, and other applications where precision welds are required at an incredible value.

The PREP 20, like the PREP 16 and PREP 24 utilise ratchet feed, and locking. This allows effortless setup, and enables the operator to deliver consistent feed with minimal effort.



Self-centering 100mm (4") one piece locking shaft with built in jaws, eliminates the issue of broken or loosening retaining springs and o-rings.



Innovative Wide locking jaws offer 6 point locking from 3 jaws giving superior clamping force for chatter free end preps.

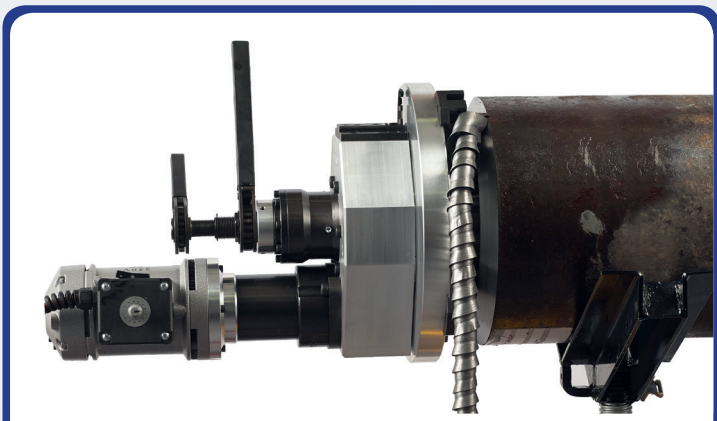
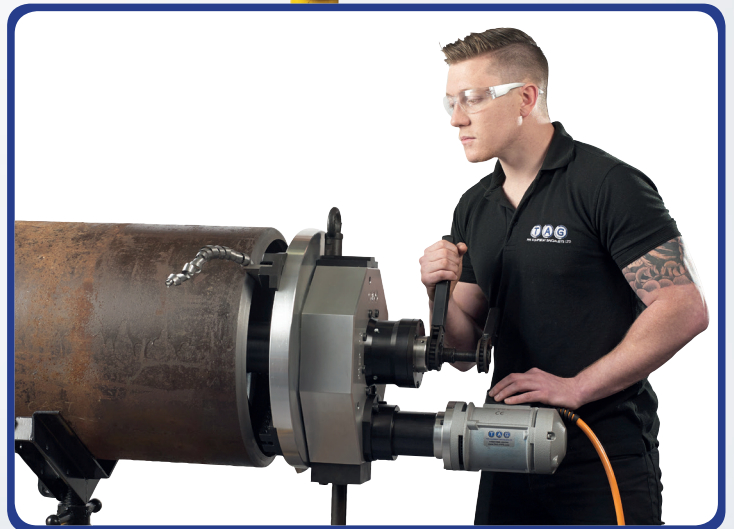
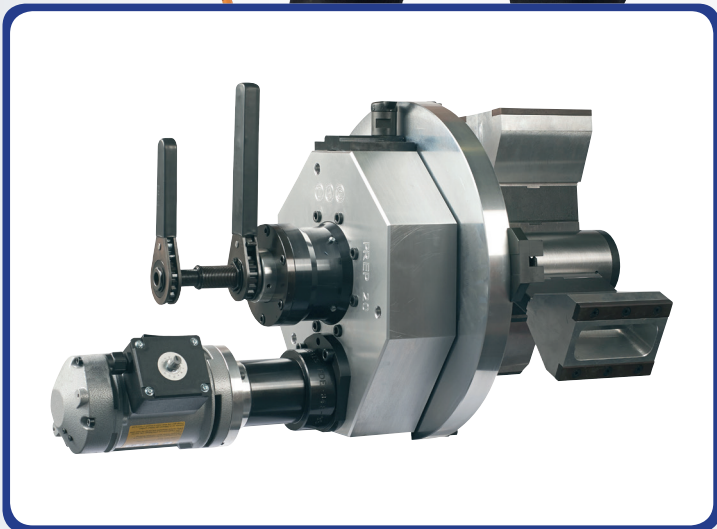

The PREP 20 has unrivalled power and stability, utilising a ratchet system for both jaw locking, and bevel feed.



The PREP 20 can also be supplied as an electric version, with a 3200 watt heavy duty, in-line or right angle motor drive, or a heavy duty 3.5 Hp Pneumatic motor.



www.TAG-PIPE.COM

Copyright © 2017 TAG PIPE EQUIPMENT SPECIALISTS LTD. All rights reserved.

Tel: +44 (0)1869 324 144
E-mail: sales@tag-pipe.com

PREP 20 TECHNICAL FEATURES:

DESCRIPTION	MEASUREMENT	PNEUMATIC	ELECTRIC
Part Number	-	TP20P	TP20E
Locking tube range	mm / inch (i/d.)	100 - 500mm / 3.9 - 19.7"	100 - 500mm / 3.9 - 19.7"
Recommended working range	mm / inch (o/d.)	100 - 508mm / 4.0 - 20.0"	100 - 508mm / 4.0 - 20.0"
Idle speed	rpm	10	2 - 10
Torque	nm	7500	7500
Length of axial feed	mm / inch	60mm / 2.4"	60mm / 2.4"
Max operating temperature	c°	55	35
Max acoustic radiation	dB	75	75
Pneumatic motor power	hp	3.5	-
Air consumption	cfm	85	-
Air working pressure	psi	90	-
Air hose connection	inches	¾"	-
Electric motor power	watt	-	3200
Voltage	volt	-	110 / 220
Frequency	Hz	-	50 / 60
Unit weight	kg / lbs	88 / 194	88 / 194
Packing dimensions	mm	970 x 630 x 675mm	970 x 630 x 675mm
Packing weight	kg / lbs	120 / 264	120 / 264

- Electric 110/220v motors only 3 month warranty period.
- All units are supplied complete with all gripping segments to cover the full range of the machine. Service tools, drawings, instruction manual and warranty certificate are also supplied as standard.
- Each machine is supplied with a protective custom built wooden crate.
- We strongly recommend the use of a portable filter lubricator with all our pneumatic models.

DIMENSIONS

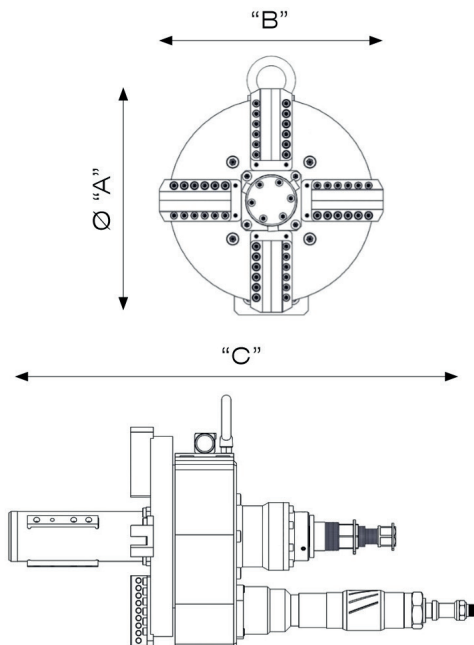

DIM	PNEUMATIC	ELECTRIC
A	510mm	510mm
B	510mm	510mm
C	860mm	775mm

EXAMPLES OF COMMON CUTTING TOOLS

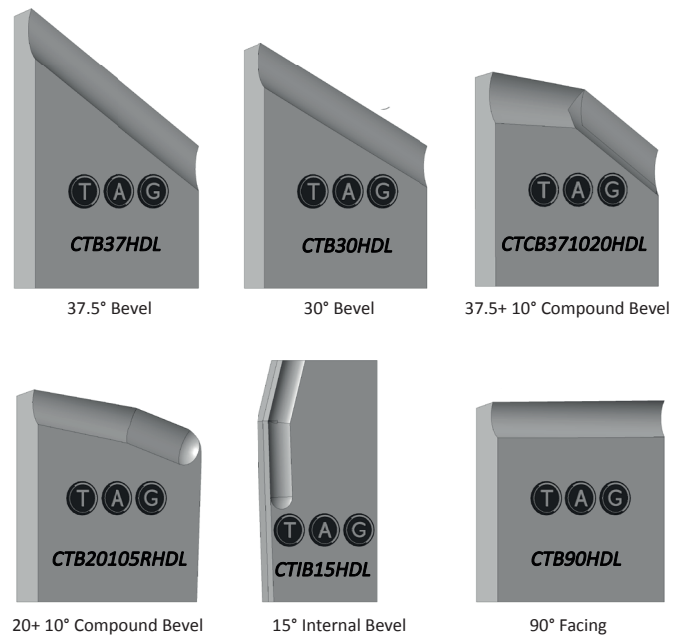

All shapes, sizes and angles available



PIPE EQUIPMENT SPECIALISTS LTD PRODUCTS INCLUDE:

PIPE BEVELLING MACHINES

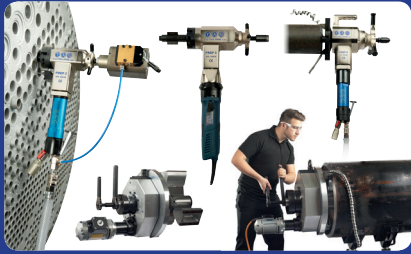

PIPE CUTTING MACHINES



PIPE ALIGNMENT CLAMPS

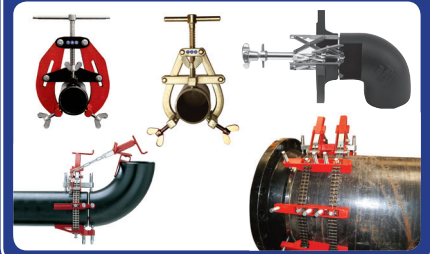

PIPE STANDS AND ROLLERS



PIPE PURGING EQUIPMENT



PLATE BEVELLERS



North America

Europe

Asia

Middle East

India

Africa

South America

Australia



TAG Head Office

TAG PIPE EQUIPMENT SPECIALISTS LTD
Unit 15 & 16 Grendon Industrial Estate, Grendon Underwood,
Aylesbury, Buckinghamshire, HP18 0QX England
Tel: +44 (0)1869 324 144 E-mail: sales@tag-pipe.com
www.TAG-PIPE.com

Your Local Distributor

Overseas Branches



USA Branch

TAG PIPE EQUIPMENT SPECIALISTS INC
527 Michigan Street, South Houston
Houston, Texas 77587, USA
Tel: +1 713 660 1427
E-mail: sales-usa@tag-pipe.com



Europe Branch

TAG PIPE EQUIPMENT SPECIALISTS BVBA
Mosten 13, 9160 Lokeren
Belgium
Tel: +32 486 46 62 93
E-mail: sales-europe@tag-pipe.com



Middle East Branch

TAG PIPE EQUIPMENT SPECIALISTS FZE
Al Ittihad Street, P.O. Box 3763
Dubai, United Arab Emirates
Tel: +971 (0)50 680 3107
E-mail: sales-me@tag-pipe.com



India Branch

TAG PIPE EQUIPMENT SPECIALISTS PVT
Plot No. PAP 3, D 3 Block,
Chinchwad, Pune 411 019
Tel: +91 20 6573 4333
E-mail: sales-india@tag-pipe.com



Asia Branch

TAG PIPE EQUIPMENT SPECIALISTS PTE
Yinhe Bridge West, Beichen District
Tianjin, China
Tel: +86 139 2001 5417
E-mail: sales-asia@tag-pipe.com

Our company policy is one of continuous improvement. Products may change or vary from those illustrated.

Copyright © 2017 TAG PIPE EQUIPMENT SPECIALISTS LTD, All rights reserved.