

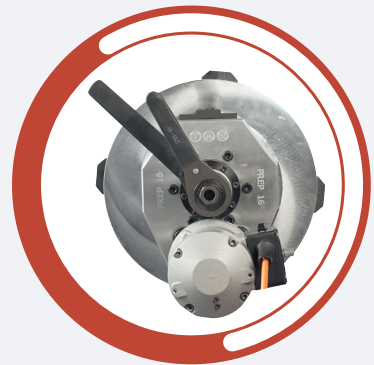

PIPE EQUIPMENT SPECIALISTS LTD

PREP 16 PIPE BEVELLING 3" to 16"

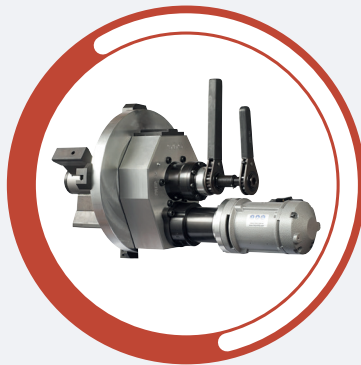
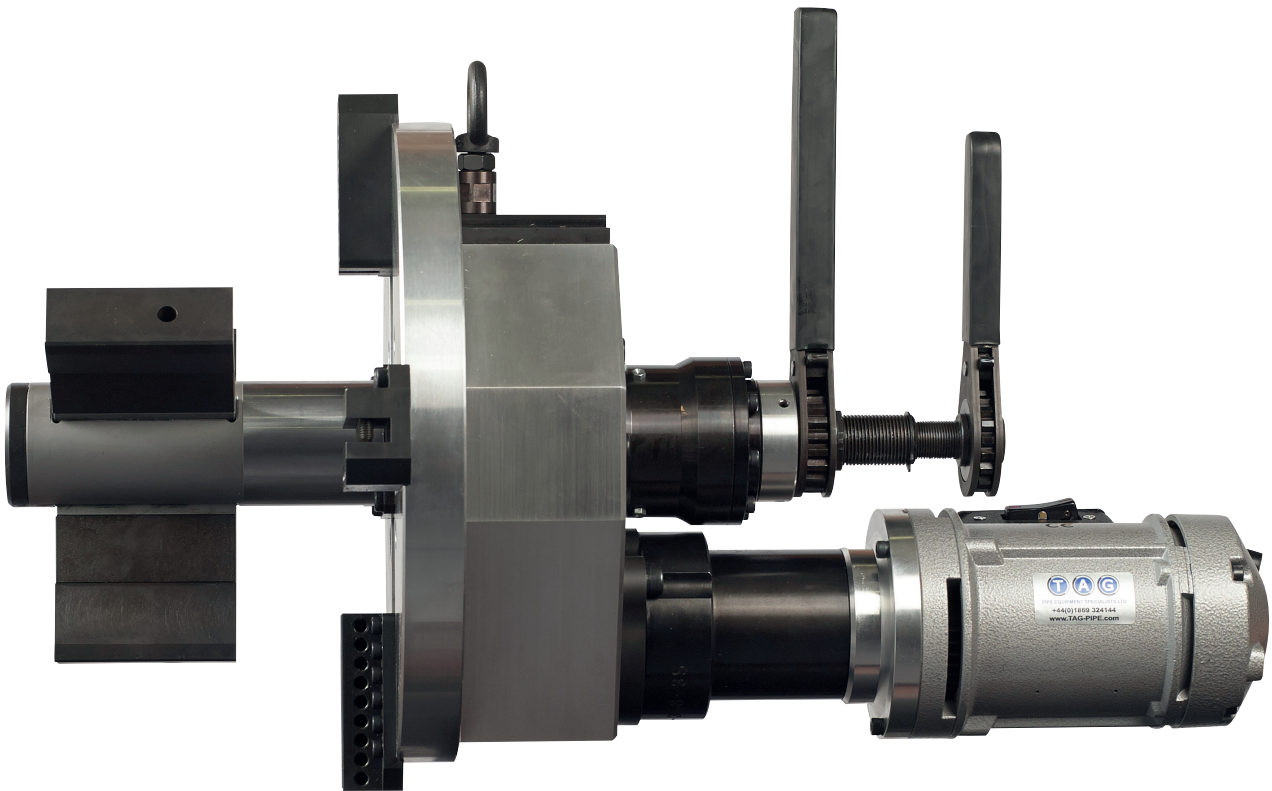

www.TAG-PIPE.com

Copyright © 2017 TAG PIPE EQUIPMENT SPECIALISTS LTD. All rights reserved.

Tel: +44 (0)1869 324 144
E-mail: sales@tag-pipe.com

RANGE: 72 to 385mm i/d

- **Functions:** External Beveling
Internal Beveling
Facing
Counter-boring
Weld Removal
J-Prepping
Compound Bevels
- **Materials:** Any kind of Steel
and Exotic Alloy
- **Power:** Pneumatic (option of
Electric 110v or 220v)



FEATURES & ADVANTAGES

The PREP 16 is the first in TAG's new range of a heavy duty mid-large diameter beveling machines.

Offering ratchet i/d jaw locking, as well as Ratchet bevel feed control for effortless heavy wall preps. Offered with a 3 HP Pneumatic or 1750 watt electric motor any bevel geometry can be performed within the impressive 3 - 16" range.

J-preps, counter boring, and facing can all be performed, simultaneously, using the correct tooling fitted in (up to) 4 heavy duty hardened multi-position tool holders. Due to its light weight, yet unrivalled power, the PREP 16 is ideal for on-site, off shore, nuclear, and other applications where precision welds are required at an incredible value.

The PREP 16, and its bigger brothers, the PREP 20, the PREP 24, all utilise ratchet feed and locking. This allows effortless set-up, and enables the operator to deliver consistent feed with minimal effort.



To enable ease of set up, the machine is equipped with a double-sided yoke with removable extensions so the machine can be easily installed, and removed from the pipe.



Self-centering 70mm (2.75") one piece locking shaft with built in jaws, eliminates the issue of broken or loosening retaining springs and o-rings.



Innovative Wide locking jaws offer 6 point locking from 3 jaws giving superior clamping force for chatter free end preps.



The PREP 16 has unrivalled power and stability, utilising a ratchet system for both jaw locking, and bevel feed.

The PREP 16 can also be supplied as an electric version, with a 1750 watt heavy duty, in-line or right angle motor drive, or a heavy duty 3.0 Hp Pneumatic motor.



www.TAG-PIPE.COM

Copyright © 2017 TAG PIPE EQUIPMENT SPECIALISTS LTD. All rights reserved.

Tel: +44 (0)1869 324 144
E-mail: sales@tag-pipe.com

PREP 16 TECHNICAL FEATURES:

| DESCRIPTION | MEASUREMENT | PNEUMATIC | ELECTRIC |
|---------------------------|------------------|--------------------------|--------------------------|
| Part Number | - | TP16P | TP16E |
| Locking tube range | mm / inch (i/d.) | 72 - 385mm / 2.8 - 15.1" | 72 - 385mm / 2.8 - 15.1" |
| Recommended working range | mm / inch (o/d.) | 72 - 406mm / 2.8 - 16" | 72 - 406mm / 2.8 - 16" |
| Idle speed | rpm | 11 - 21 | 2 - 21 |
| Torque | nm | 1770+ | 1770+ |
| Length of axial feed | mm / inch | 50mm / 2" | 50mm / 2" |
| Max operating temperature | c° | 55 | 35 |
| Max acoustic radiation | dB | 75 | 75 |
| Pneumatic motor power | hp | 3.0 | - |
| Air consumption | cfm | 70 | - |
| Air working pressure | psi | 90 | - |
| Air hose connection | inches | ¾" | - |
| Electric motor power | watt | - | 1750 |
| Voltage | volt | - | 110 / 220 |
| Frequency | Hz | - | 50 / 60 |
| Unit weight | kg / lbs | 40 / 88 | 40 / 88 |
| Packing dimensions | mm | 760 x 500 x 560mm | 760 x 500 x 560mm |
| Packing weight | kg / lbs | 75 / 165 | 75 / 165 |

- Electric 110/220v motors only 3 month warranty period.
- All units are supplied complete with all gripping segments to cover the full range of the machine. Service tools, drawings, instruction manual and warranty certificate are also supplied as standard.
- Each machine is supplied with a protective custom built wooden crate.
- We strongly recommend the use of a portable filter lubricator with all our pneumatic models.

DIMENSIONS

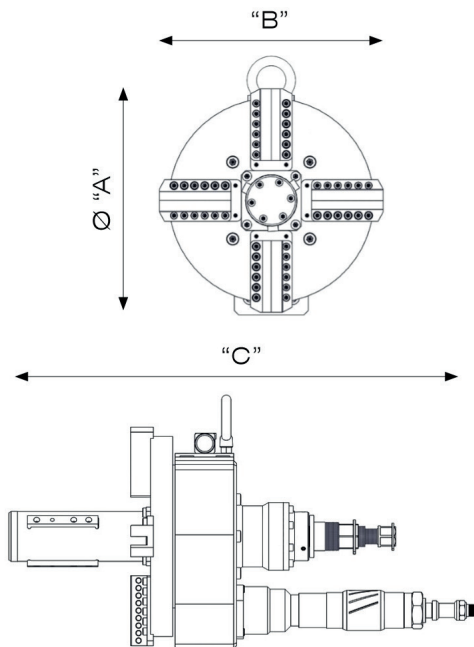

| DIM | PNEUMATIC | ELECTRIC |
|-----|-----------|----------|
| A | 407mm | 407mm |
| B | 407mm | 407mm |
| C | 750mm | 630mm |

EXAMPLES OF COMMON CUTTING TOOLS

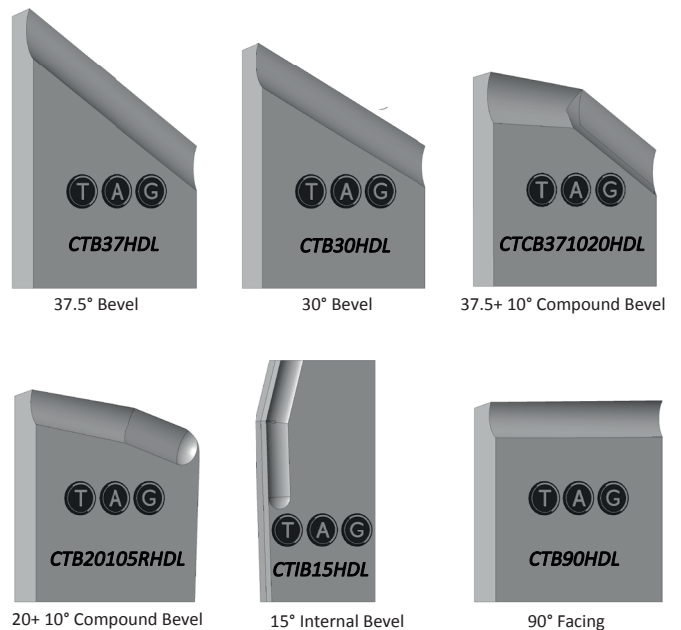

All shapes, sizes and angles available



PIPE EQUIPMENT SPECIALISTS LTD PRODUCTS INCLUDE:

PIPE BEVELLING MACHINES

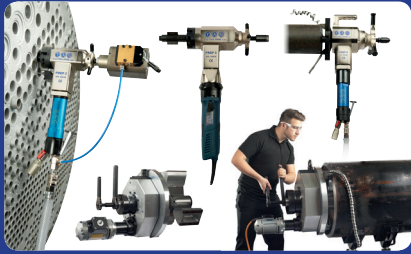

PIPE CUTTING MACHINES



PIPE ALIGNMENT CLAMPS

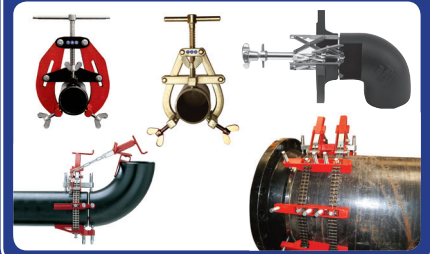

PIPE STANDS AND ROLLERS



PIPE PURGING EQUIPMENT



PLATE BEVELLERS



North America

Europe

Asia

Middle East

India

Africa

South America

Australia



TAG Head Office

TAG PIPE EQUIPMENT SPECIALISTS LTD
Unit 15 & 16 Grendon Industrial Estate, Grendon Underwood,
Aylesbury, Buckinghamshire, HP18 0QX England
Tel: +44 (0)1869 324 144 E-mail: sales@tag-pipe.com
www.TAG-PIPE.com

Your Local Distributor

Overseas Branches



USA Branch

TAG PIPE EQUIPMENT SPECIALISTS INC
527 Michigan Street, South Houston
Houston, Texas 77587, USA
Tel: +1 713 660 1427
E-mail: sales-usa@tag-pipe.com



Europe Branch

TAG PIPE EQUIPMENT SPECIALISTS BVBA
Mosten 13, 9160 Lokeren
Belgium
Tel: +32 486 46 62 93
E-mail: sales-europe@tag-pipe.com



Middle East Branch

TAG PIPE EQUIPMENT SPECIALISTS FZE
Al Ittihad Street, P.O. Box 3763
Dubai, United Arab Emirates
Tel: +971 (0)50 680 3107
E-mail: sales-me@tag-pipe.com



India Branch

TAG PIPE EQUIPMENT SPECIALISTS PVT
Plot No. PAP 3, D 3 Block,
Chinchwad, Pune 411 019
Tel: +91 20 6573 4333
E-mail: sales-india@tag-pipe.com



Asia Branch

TAG PIPE EQUIPMENT SPECIALISTS PTE
Yinhe Bridge West, Beichen District
Tianjin, China
Tel: +86 139 2001 5417
E-mail: sales-asia@tag-pipe.com

Our company policy is one of continuous improvement. Products may change or vary from those illustrated.

Copyright © 2017 TAG PIPE EQUIPMENT SPECIALISTS LTD, All rights reserved.